



**DIVISION: 03 00 00—CONCRETE**  
**Section: 03 16 00—Concrete Anchors**

**DIVISION: 05 00 00—METALS**  
**Section: 05 05 23—Metal Fastenings**

**REPORT HOLDER:**

**HILTI, INC.**

**EVALUATION SUBJECT:**

**HILTI LOW-VELOCITY POWER-ACTUATED X-DR, X-DR MX AND X-HS ROD HANGER ASSEMBLIES AND X-MW ALH AND X-MW MX WIRE HANGER ASSEMBLIES**

**1.0 EVALUATION SCOPE**

**Compliance with the following codes:**

- 2021, 2018, 2015, 2012 and 2009 *International Building Code*® (IBC)
- 2021, 2018, 2015, 2012 and 2009 *International Residential Code*® (IRC)
- 2013 *Abu Dhabi International Building Code* (ADIBC)<sup>†</sup>

<sup>†</sup>The ADIBC is based on the 2009 IBC. 2009 IBC code sections referenced in this report are the same sections in the ADIBC.

For evaluation for compliance with codes adopted by Los Angeles Department of Building and Safety (LADBS), see [ESR-2795 LABC and LARC Supplement](#).

**Property evaluated:**

Structural

**2.0 USES**

Hilti X-DR, X-DR MX and X-HS low-velocity, power-actuated, rod hanger assemblies and the X-MW ALH and X-MW MX low velocity, power-actuated wire hanger assemblies are used as alternatives to the cast-in-place anchors described in IBC Section 1901.3 (2012 IBC Section 1908; 2009 IBC Section 1911) for placement in concrete, and the welds and bolts used to attach materials to steel, described in IBC Sections 2204.1 and 2204.2, respectively. The rod hanger assemblies are used to connect smooth and threaded steel rods to the supporting material. The wire hanger assemblies are used to connect wire to the supporting material. For structures regulated under the IRC, the rod and wire hanger assemblies may be used where an engineered design is submitted in accordance with IRC Section R301.1.3.

**3.0 DESCRIPTION**

**3.1 X-DR Rod Hanger Assemblies:**

The Hilti X-DR rod hanger assembly is intended to resist tension loads only. The assembly consists of an X-ALH low velocity, power-actuated fastener with a premounted steel angle/coupler/rod assembly. The Hilti X-DR rod hanger is available in two assemblies, X-DR ALH22 and X-DR ALH27, for which Hilti X-ALH22 and X-ALH27 fasteners are used, respectively. See Figure 1 for an illustration of the X-DR rod hanger assembly.

**3.1.1 Fastener:** The X-ALH fastener is formed from carbon steel and is heat-treated to a nominal core hardness of 58 HRC. The fastener has a smooth tapered shank, with a nominal diameter beyond the taper of 0.177 inch and a head diameter of 0.322 inch. The shank length is 0.87 inch (22mm) for the X-ALH22 fastener and 1.06 inch (27 mm) for the X-ALH27 fastener. The fastener has a zinc coating and is assembled with a plastic washer.

**3.1.2 Angle:** The steel angle is manufactured from zinc-coated cold-formed steel complying with Hilti's specifications.

**3.1.3 Rivet and Coupler:** The galvanized steel rivet is used to attach the galvanized steel coupler to the angle. The galvanized steel coupler has an internal threaded hole of 1/4-inch-diameter (6.4 mm) to accommodate connection of a rod.

**3.1.4 Rods:** The rods are galvanized steel. Smooth rods with a threaded end and threaded rods of various lengths are available. The smooth rods have a nominal diameter of 0.215 inch (5.45 mm) and a minimum tensile strength of 87 ksi (600MPa). The threaded rods have a 1/4-20 UNC-2A thread and a minimum tensile strength of 87 ksi (600MPa). The rods are supplied with a plastic cap at the unconnected end.

**3.2 X-DR MX Assembly:**

The Hilti X-DR MX rod hanger assemblies are intended to resist tension loads only. Each assembly consist of a steel bracket, coupler and rod. The assemblies are installed in the field with Hilti X-S 14 B3 or X-P 20 B3 fasteners (addressed in [ESR-1752](#)). See Figure 2 for an illustration of the X-DR MX rod hanger assembly.

**3.2.1 Bracket:** The steel bracket is manufactured from zinc-coated cold-formed steel complying with Hilti's specifications. The steel is bent to produce a uniquely shaped bracket. The long leg of the bracket has a hole with a nominal diameter of 0.169 inch (4.3 mm) to accommodate the field installed power-actuated fastener.

**3.2.2 Rivet and Coupler:** The galvanized steel rivet is used to attach the galvanized steel coupler to the bracket. The galvanized steel coupler has an internal threaded hole of 1/4-inch-diameter (6.4 mm) to accommodate connection of a rod.

**3.2.3 Rods:** The rods are galvanized steel. Smooth and threaded rods of various lengths are available. One end of each smooth rod is threaded to match the threads in the coupler. The smooth rods have a nominal diameter of 0.215 inch (5.45 mm) and a minimum tensile strength of 87 ksi (600MPa). The threaded rods have a 1/4-20 UNC-2A thread [minor diameter of 0.189 inch (4.8 mm)] and a minimum tensile strength of 87 ksi (600MPa). The rods are supplied with a plastic cap at the unconnected end.

### 3.3 X-HS Threaded Rod Hanger Assembly:

The Hilti X-HS threaded rod hanger assembly is intended to resist tension, shear, and combined tension and shear loads. The assembly consists of a Hilti X-U low velocity, power-actuated fastener (addressed in [ESR-2269](#)) with two premounted washers (one of zinc-plated steel, one of plastic), and a premounted cold-formed steel bracket (threaded rod hanger) having a 1/4- or 3/8-inch-diameter (6.4 or 9.5 mm) internally threaded hole to accommodate connection of 1/4- or 3/8-inch-diameter (6.4 or 9.5 mm) UNC threaded steel rods, respectively. The X-HS U19 and X-HS U32 hanger assemblies described in this report, include Hilti X-U19 and X-U32 fasteners, respectively, addressed in [ESR-2269](#). The X-U19 and X-U32 fasteners have shank lengths of 0.75 inch (19 mm) and 1.26 inches (32 mm), respectively. The threaded rod hangers are manufactured from mild carbon steel with a zinc coating in accordance with Hilti's specifications. See Figure 3 for an illustration of the X-HS threaded rod hanger assembly.

### 3.4 X-MW ALH Wire Hanger Assemblies:

The Hilti X-MW ALH wire hanger assemblies are intended to resist tension and combined tension and shear loads. The assemblies consist of an X-ALH low velocity, power-actuated fastener with a premounted steel clip, and a length of wire rope which is attached at the manufacturing facility. Available variations of the Hilti X-MW ALH wire hanger assemblies are described in Table 4. A loop lock or channel lock mechanism (designated L or CL, respectively) is supplied with each clip assembly. Clip assemblies are supplied in packages of 30. See Figure 4 for an illustration of an X-MW AL wire hanger assembly.

**3.4.1 Clip:** The steel clip is manufactured from zinc-coated cold-formed steel complying with Hilti's specifications. The clip has a tear-shaped hole with a nominal diameter of 0.3 inch (7.5 mm) through which the wire is attached.

**3.4.2 Fastener:** The X-ALH fasteners are formed from carbon steel and are heat-treated to a nominal core hardness of 58 HRC. The fasteners have a smooth tapered shank, with a nominal diameter beyond the taper of 0.177 inch and a head diameter of 0.322 inch. The shank length is 0.87 inch (22 mm) for the X-ALH22 fastener, 1.06 inch (27 mm) for the X-ALH27 fastener and 1.26 inch (32 mm) for the X-ALH32 fastener. The fastener has a zinc coating and is assembled with a plastic washer.

**3.4.3 Wire Rope:** A length of wire rope is looped through the hole in the clip and crimped together with a ferrule. The wire rope complies with ASTM A1023 and has a 7x7 strand structure with an outer diameter of 2 mm. Available lengths are shown in Table 4.

### 3.5 X-MW MX Wire Hanger Assemblies:

The Hilti X-MW MX wire hanger assemblies are intended to resist tension loads only. Each assembly consists of a steel bracket with a length of wire rope which is attached at the manufacturing facility. The bracket must be installed with a

power-actuated fastener, which is supplied separately. A loop lock mechanism is supplied with each bracket. Brackets are supplied in packages of 30. See Figure 5 for an illustration of the X-MW MX wire hanger assembly

**3.5.1 Bracket:** The steel bracket is manufactured from zinc-coated cold-formed steel complying with Hilti's specifications. The steel is bent to produce a uniquely shaped bracket. The long leg of the bracket has a hole with a nominal diameter of 0.169 inch (4.3 mm) to accommodate the field installed power-actuated fastener. The short leg of the bracket has a hole through which the wire is attached.

**3.5.2 Wire Rope:** A length of wire rope is looped through the hole in the short leg of the bracket and crimped together with a ferrule. The wire rope complies with ASTM A1023 and has a 7x7 strand structure with an outer diameter of 2 mm. Available lengths are 6 feet (2 m), 10 feet (3 m) and 20 feet (6 m).

**3.5.3 Fastener:** Each bracket must be installed with a Hilti X-S 14 B3 or X-P 20 B3 fastener, which are addressed in ESR-1752.

### 3.6 Substrate Materials:

**3.6.1 Steel:** Structural steel used in supports must comply with the minimum strength requirements of ASTM A36, A572 Grade 50 or A992, and must have a minimum thickness of 3/16-inch (4.76 mm).

**3.6.2 Concrete:** Normalweight and sand-lightweight concrete must comply with IBC Chapter 19 or IRC Section R402.2, as applicable. The minimum concrete compressive strength at the time of fastener installation must be as noted in the applicable allowable load table.

**3.6.3 Steel Deck Panels:** Steel deck panel properties and configurations must be as described in the footnotes to Table 3. See Figures 10 through 13 for panel configuration requirements.

## 4.0 DESIGN AND INSTALLATION

### 4.1 Design:

**4.1.1 Allowable Loads:** The allowable tension, shear and 45-degree-angle loads for X-DR, X-DR MX and X-HS rod hanger assemblies and X-MW MX wire hanger assemblies installed into steel are provided in Table 1. The allowable tension, shear and 45-degree-angle loads for X-DR, X-DR MX and X-HS rod hanger assemblies and X-MW ALH and X-MW MX wire hanger assemblies installed into normalweight concrete are provided in Table 2. The allowable tension, shear and 45-degree-angle loads for X-DR, X-DR MX and X-HS rod hanger assemblies and X-MW ALH and X-MW MX wire hanger assemblies installed into sand-lightweight concrete and into sand-lightweight concrete filled steel deck panels are provided in Table 3.

The most critical applied loads, excluding seismic load effects, resulting from the load combinations in Section 2.4 of ASCE 7-16/S1 (referenced in 2021 IBC Section 1605.1) or 2021 IBC Section 1605.2 (Section 1605.3.1 or 1605.3.2 of the 2018, 2015, 2012 and 2009 IBC) must not exceed the allowable loads. For assemblies subjected to seismic loads, see Section 4.1.3 for additional information. The stress increases and load reductions described in 2021 IBC Section 1605.2 (2018, 2015, 2012 and 2009 IBC Section 1605.3) are not allowed.

Allowable loads apply to the connection of the X-DR, X-DR MX and X-HS Hanger Assembly to the base material only with threaded rod installed; and to the connection of the X-MW ALH and X-MW MX wire hanger assemblies to the base material only. Design of the connection of the hanger assemblies to the suspended materials must comply with the applicable requirements of the IBC.

**4.1.2 Combined Loading:** For assemblies subjected to both shear and tension forces, compliance with the following interaction equation must be verified:

$$(p/P_a) + (v/V_a) \leq 1$$

where:

- $p$  = Actual applied tension load on fastener, lbf (N).
- $P_a$  = Allowable tension load on fastener, lbf (N).
- $v$  = Actual applied shear load on fastener, lbf (N).
- $V_a$  = Allowable shear load on fastener, lbf (N).

Exception: Hilti X-HS rod hanger assemblies and X-MW ALH wire hanger assemblies loaded at 45 degrees have the allowable loads shown in the tables of this report.

**4.1.3 Seismic Considerations:** The Hilti X-DR, X-DR MX and X-HS rod hanger assemblies and X-MW ALH and X-MW MX wire hanger assemblies have been evaluated for use when subjected to seismic loads as follows:

1. The Hilti X-DR, X-DR MX and X-HS rod hanger assemblies and X-MW ALH and X-MW MX wire hanger assemblies may be used for attachment of nonstructural components listed in Section 13.1.4 of ASCE 7, which are exempt from the requirements of ASCE/SEI 7.
2. Concrete Base Materials: The Hilti X-DR, X-DR MX and X-HS rod hanger assemblies and X-MW ALH and X-MW MX wire hanger assemblies fastened to concrete may be used to support acoustical tile or lay-in panel suspended ceiling systems, distributed systems and distribution systems where the service load on any individual X-DR, X-DR MX or X-HS rod hanger assembly or any individual X-MW ALH or X-MW MX wire hanger assembly does not exceed the lesser of 90 lbf (400 N) or the published allowable load shown in Table 2 or 3, as applicable.
3. Steel Base Materials: The Hilti X-DR, X-DR MX and X-HS rod hanger assemblies and X-MW MX wire hanger assemblies fastened to steel may be used where the service load on any individual X-DR, X-DR MX or X-HS rod hanger assembly or any individual X-MW MX wire hanger assembly does not exceed the lesser of 250 lbf (1112 N) or the published allowable load shown in Table 1.

## 4.2 Installation:

**4.2.1 General:** The X-DR, X-DR MX and X-HS rod hanger assemblies and X-MW ALH and X-MW MX wire hanger assemblies must be installed in accordance with this report and the Hilti, Inc., published installation instructions, including those shown in Figures 6, 7 and 8, as applicable. A copy of these instructions must be available on the jobsite at all times during installation. Installation is limited to dry, interior locations.

Fastener placement requires the use of a low-velocity power-actuated or electro-mechanically-actuated tool in accordance with Hilti, Inc. recommendations. Nailhead standoff distance must be as noted in the footnotes to Tables 1, 2 and 3, and as shown in Figures 6, 7 and 8, as applicable. Installers using power-actuated tools must be certified by Hilti and have a current, Hilti-issued, operator's license.

**4.2.2 Fastening to Steel:** When installation is in steel, minimum spacing between fasteners must be 1 inch (25.4 mm) and minimum edge distance must be 1/2 inch (12.7 mm).

**4.2.3 Fastening to Concrete:** Fasteners must be driven into the normalweight or sand-lightweight concrete after the concrete attains the specified concrete compressive strength. Unless otherwise noted, minimum spacing between fasteners must be 4 inches (102 mm) and minimum edge distance must be 3 inches (76 mm). Unless otherwise noted in this report, concrete thickness must be a minimum of 3 inches (76 mm).

**4.2.4 Fastening to Sand-lightweight Concrete Filled Steel Deck Panels:** Installation in sand-lightweight concrete filled steel deck panels must comply with Figures 10 through 13. Minimum distances from fastener centerline to rolled deck panel flute edges must be as depicted in Figures 10 through 13.

## 5.0 CONDITIONS OF USE

The Hilti X-DR, X-DR MX or X-HS rod hanger assemblies and X-MW ALH and X-MW MX wire hanger assemblies described in this report comply with, or are suitable alternatives to what is specified in, those codes listed in Section 1.0 of this report, subject to the following conditions:

- 5.1** The hanger assemblies are manufactured and identified in accordance with this report.
- 5.2** Hanger assembly installation complies with this report and the Hilti, Inc., published instructions. In the event of conflict between this report and Hilti, Inc., published instructions, this report governs.
- 5.3** Calculations demonstrating that the applied loads are less than the allowable loads described in this report must be submitted to the code official for approval. The calculations must be prepared by a registered design professional where required by the statutes of the jurisdiction in which the project is constructed.
- 5.4** Refer to Section 4.1.3 for seismic considerations.
- 5.5** The use of the hanger assemblies is limited to installation in uncracked concrete. Cracking occurs when  $f_t > f_r$  due to service loads or deformations.
- 5.6** Use of the hanger assemblies is limited to dry, interior locations.
- 5.7** Evaluation of the hanger wire, loop lock and channel lock components of the wire hanger assemblies is outside the scope of this report.
- 5.8** The Hilti products addressed in this report are manufactured under a quality-control program with inspection by ICC-ES.

## 6.0 EVIDENCE SUBMITTED

Data in accordance with the ICC-ES Acceptance Criteria for Power-actuated Fasteners Driven into Concrete, Steel and Masonry Elements (AC70), dated February 2016 (editorially revised January 2021).

## 7.0 IDENTIFICATION

- 7.1** All hanger assemblies are identified on the packaging, with the Hilti, Inc. name, the hanger type, the fastener type and size (as applicable, when included with the hanger), and the evaluation report number (ESR-2795). Products are marked as follows:
  - 7.1.1 X-DR:** The word "Hilti" and the designation "X-DR" are stamped on the angle. The X-ALH fastener is imprinted with an "H" on the head.
  - 7.1.2 X-DR MX:** The word "Hilti" and the designation "X-DR MX" are stamped on the bracket.

- 7.1.3 **X-HS:** The word “Hilti” and the designation “X-HS” are stamped on the hanger. The X-U fastener is imprinted with an “H” on the head.
- 7.1.4 **X-MW ALH:** The word “Hilti” and the designation “X-CX” are stamped on the clip. The X-ALH fastener is imprinted with an “H” on the head.
- 7.1.5 **X-MW MX:** The word “Hilti” and the designation “X-MW MX” are stamped on the bracket.

7.2 The report holder’s contact information is the following:

**HILTI, INC.**  
**7250 DALLAS PARKWAY, SUITE 1000**  
**PLANO, TEXAS 75024**  
**(800) 879-8000**  
[www.hilti.com](http://www.hilti.com)

**TABLE 1—ALLOWABLE LOADS FOR HILTI ROD AND WIRE HANGER ASSEMBLIES DRIVEN INTO STEEL (lbf)<sup>1,2</sup>**

HANGER ASSEMBLY	ALLOWABLE LOADs (lbf)				
	Steel Thickness (inch):	<sup>3/16</sup>			<sup>1/4</sup>
Loading Direction:	Tension	Shear	45-degree	Tension	Tension
X-DR ALH22	100	–	–	100	100
X-DR MX installed with an X-S 14 B3 fastener	90	–	–	85	80
X-MW MX installed with an X-S 14 B3 fastener	90	–	–	85	80
X-HS U19 <sup>(3,4)</sup>	270	220	275 <sup>5</sup>	–	–

For **SI**: 1 inch = 25.4 mm, 1 lbf = 4.45 N.

<sup>1</sup>Allowable load capacities apply to base steel with minimum yield strength ( $F_y$ ) of 36 ksi, a minimum tensile strength ( $F_u$ ) of 58 ksi and a minimum thickness of <sup>3/16</sup>-inch.

<sup>2</sup>Nailhead Standoff,  $h_{NVS}$ , for the X-DR and X-HS assemblies must be less than or equal to <sup>3/8</sup> inch. Nailhead Standoff,  $h_{NVS}$ , for the X-DR MX and X-MW MX assemblies must be less than or equal to <sup>1/4</sup> inch, and as indicated in the Hilti installation instructions. See Figures 6, 7 and 8, as applicable.

<sup>3</sup>Allowable loads apply to X-HS threaded rod hanger assemblies with either the <sup>1/4</sup>- or <sup>3/8</sup>-inch-diameter internally threaded hole.

<sup>4</sup>See Figures 9a, 9b and 9c for load directions for the X-HS assemblies.

<sup>5</sup>Allowable loads for 45-degree applications are based on testing. For allowable loads at other angles of installation, refer to Section 4.1.2.

**TABLE 2—ALLOWABLE LOADS FOR HILTI ROD AND WIRE HANGER ASSEMBLIES INSTALLED IN NORMALWEIGHT CONCRETE<sup>1,2,3</sup>**

HANGER ASSEMBLY	ALLOWABLE LOADS (lbf)							
	2500 psi			4000 psi			6,000	
Concrete Compressive Strength:	Tension	Shear	45-degree	Tension	Shear	45-degree	Tension	45-degree
X-DR ALH22	–	–	–	40	–	–	–	–
X-DR ALH27	–	–	–	50	–	–	100	–
X-DR MX installed with an X-P 20 B3 fastener	–	–	–	30	–	–	–	–
X-MW ALH22	–	–	–	60	–	100	60	60
X-MW ALH27	–	–	–	100	–	100	100	100
X-MW ALH32	–	–	–	100	–	100	100	100
X-MW MX installed with an X-P 20 B3 fastener	–	–	–	30	–	–	–	–
X-HS U32 <sup>(4,5)</sup>	75	100	60 <sup>6</sup>	85	150	120 <sup>6</sup>	–	–

For **SI**: 1 inch = 25.4 mm, 1 lbf = 4.4 N, 1 psi = 6895 Pa.

<sup>1</sup>Fasteners must not be driven until the concrete has reached the specified compressive strength.

<sup>2</sup>Concrete material thickness at the point of penetration must be a minimum of 3 inches.

<sup>3</sup>Nailhead Standoff,  $h_{NVS}$ , must be less than or equal to <sup>3/8</sup> inch, unless otherwise noted. Nailhead Standoff must be less than or equal to <sup>5/16</sup> inch, for the X-MW ALH assemblies, less than or equal to <sup>3/16</sup> inch for the X-DR MX and X-MW MX assemblies, and as indicated in the Hilti installation instructions. See Figures 6, 7 and 8, as applicable.

<sup>4</sup>Allowable loads apply to X-HS threaded rod hanger assemblies with either the <sup>1/4</sup>- or <sup>3/8</sup>-inch-diameter internally threaded hole.

<sup>5</sup>See Figures 9a, 9b and 9c for load directions for the X-HS assemblies.

<sup>6</sup>Allowable loads for 45-degree applications are based on testing. For allowable loads at other angles of installation, refer to Section 4.1.2.



**TABLE 3—ALLOWABLE LOADS FOR HILTI ROD AND WIRE HANGER ASSEMBLIES INSTALLED INTO SAND-LIGHTWEIGHT CONCRETE AND COMPOSITE STEEL DECK PANELS<sup>1,2,3,4,5,6,7,9</sup>**

HANGER ASSEMBLY	ALLOWABLE LOADS (lbf)														
Fastener Location:	Installed into Structural Sand-lightweight Concrete			Installed through 1 1/2 in. Deep Steel Deck Panel Into Sand-lightweight Concrete						Installed through 3 in. Deep Steel Deck Panel Into Sand-lightweight Concrete					
				Upper Flute			Lower Flute			Upper Flute			Lower Flute		
Load Direction:	Tension	Shear	45-degree	Tension	Shear	45-degree	Tension	Shear	45-degree	Tension	Shear	45-degree	Tension	Shear	45-degree
X-DR ALH22	–	–	–	–	–	–	–	–	–	100 <sup>(10)</sup>	–	–	40 <sup>(10)</sup>	–	–
X-DR ALH27	–	–	–	–	–	–	–	–	–	100 <sup>(10)</sup>	–	–	80 <sup>(10)</sup>	–	–
X-DR MX installed with an X-P 20 B3 fastener	–	–	–	–	–	–	–	–	–	80 <sup>(10)</sup>	–	–	60 <sup>(10)</sup>	–	–
X-MW ALH22	–	–	–	–	–	–	–	–	–	100	–	100	90	–	100
X-MW ALH27	–	–	–	–	–	–	–	–	–	100	–	100	100	–	100
X-MW ALH32	–	–	–	–	–	–	–	–	–	100	–	100	100	–	100
X-MW MX installed with an X-P 20 B3 fastener	–	–	–	–	–	–	–	–	–	80 <sup>(10)</sup>	–	–	60 <sup>(10)</sup>	–	–
X-HS U32	95	115	105 <sup>8</sup>	95	220	135 <sup>8</sup>	95	220	135 <sup>8</sup>	125	220	175 <sup>8</sup>	95	220	135 <sup>8</sup>

For **SI**: 1 inch = 25.4 mm, 1 lbf = 4.4 N, 1 psi = 6895 Pa.

<sup>1</sup>Fasteners must not be driven until the concrete has reached the specified compressive strength.

<sup>2</sup>Concrete material thickness at the point of penetration must be a minimum of 3 inches, except as shown in Figures 10 through 13.

<sup>3</sup>Deck panel must have a minimum No. 20 gage (0.0359 inch) base-metal thickness and a minimum yield strength of 33,000 psi.

<sup>4</sup>Nailhead Standoff,  $h_{NVS}$ , must be less than or equal to 1/4 inch for the X-DR, less than or equal to 5/16 inch for the X-MW ALH assemblies, less than or equal to 3/16 inch for the X-DR MX and X-MW MX assemblies, less than or equal to 3/8 inch for the X-HS U32 hanger assembly and as indicated in the Hilti installation instructions. See Figures 6, 7 and 8, as applicable.

<sup>5</sup>Allowable loads apply to X-HS threaded rod hanger assemblies with either the 1/4- or 3/8-inch-diameter internally threaded hole.

<sup>6</sup>See Figures 9a, 9b and 9c for load directions for the X-HS assemblies.

<sup>7</sup>See Figures 10 through 13 for nominal flute dimensions, fastener locations, and load orientations.

<sup>8</sup>Allowable loads for 45-degree applications are based on testing. For allowable loads at other angles of installation, refer to Section 4.1.2.

<sup>9</sup>Allowable loads are for concrete with minimum  $f_c$  of 3,000 psi, unless otherwise noted.

<sup>10</sup>Allowable loads are for concrete with minimum  $f_c$  of 3,500 psi.

**TABLE 4—X-MW ALH WIRE HANGER ASSEMBLY VARIATIONS**

CLIP ASSEMBLY NUMBER	FASTENER	WIRE LENGTH [feet (m)]
X-MW ALH22	X-ALH-22	10 (3)
X-MW ALH27	X-ALH-27	6 (2)
		10 (3)
		20 (6)
X-MW ALH32	X-ALH-32	10 (3)



**FIGURE 1 – X-DR ROD HANGER ASSEMBLY**



**FIGURE 2 – X-DR MX ROD HANGER ASSEMBLY**



FIGURE 3—X-HS ROD HANGER ASSEMBLY



FIGURE 4 – X-MW ALH WIRE HANGER ASSEMBLY



FIGURE 5 – X-MW MX WIRE HANGER BRACKET

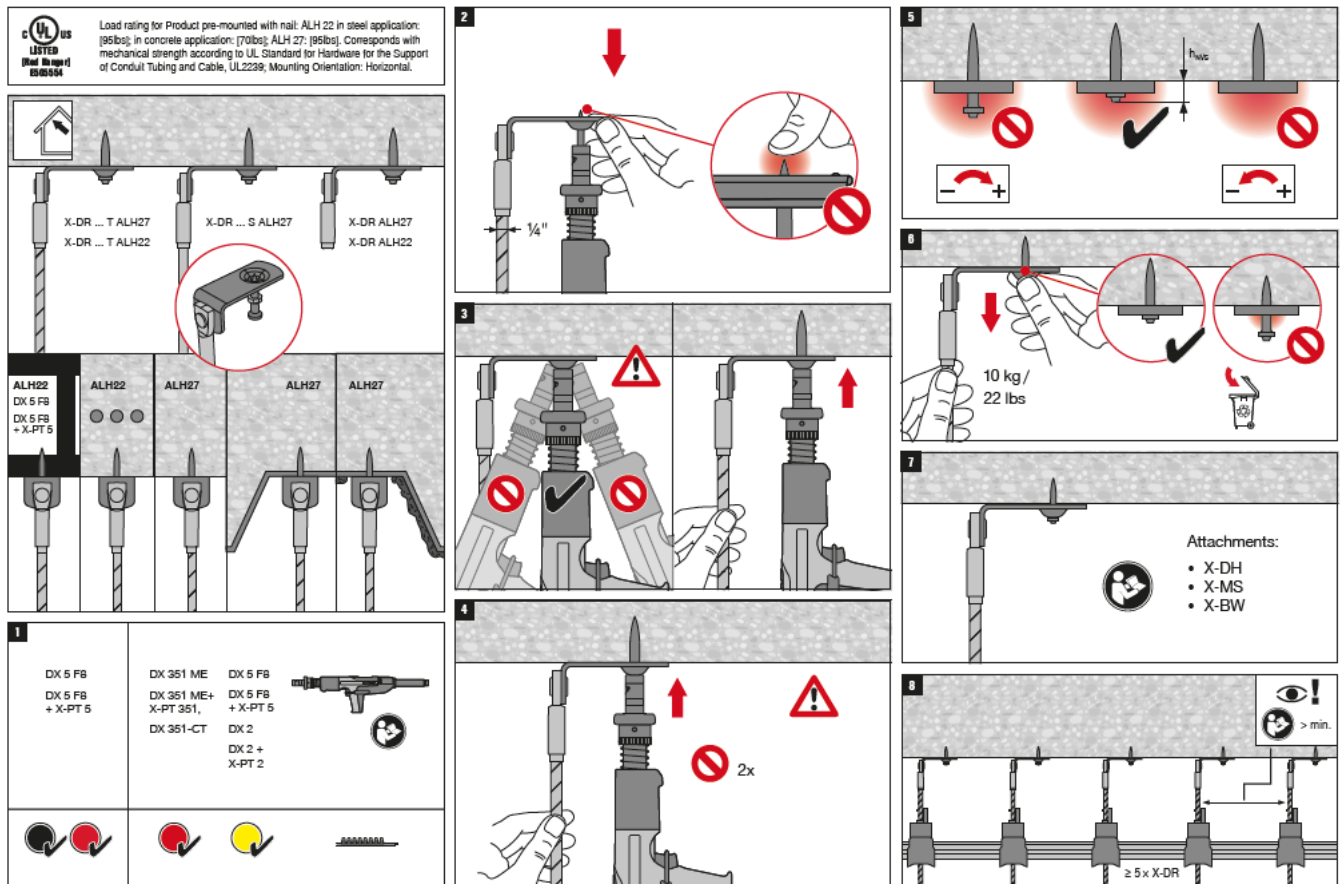

FIGURE 6—X-DR INSTALLATION INSTRUCTIONS

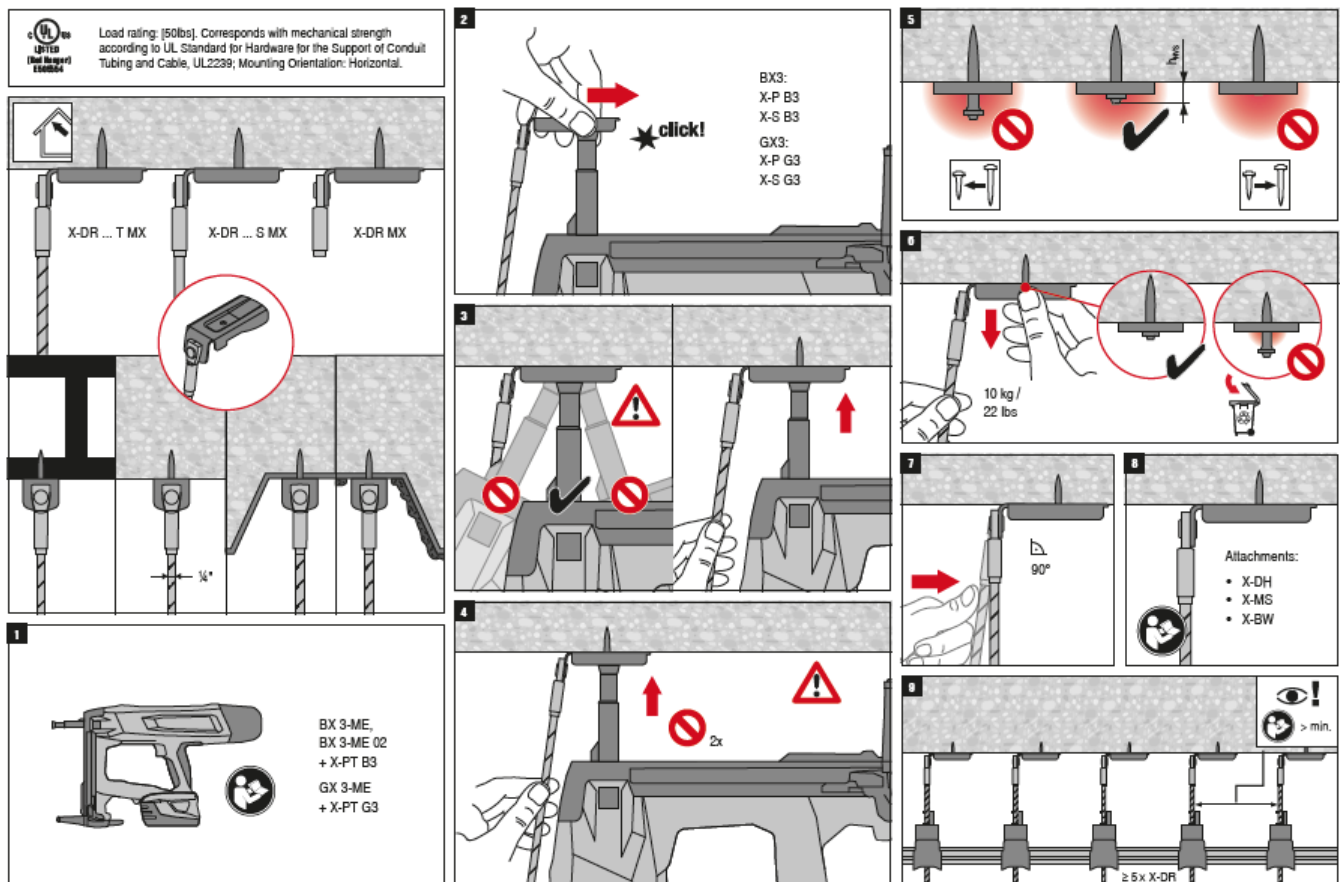

FIGURE 7 – X-DR MX INSTALLATION INSTRUCTIONS

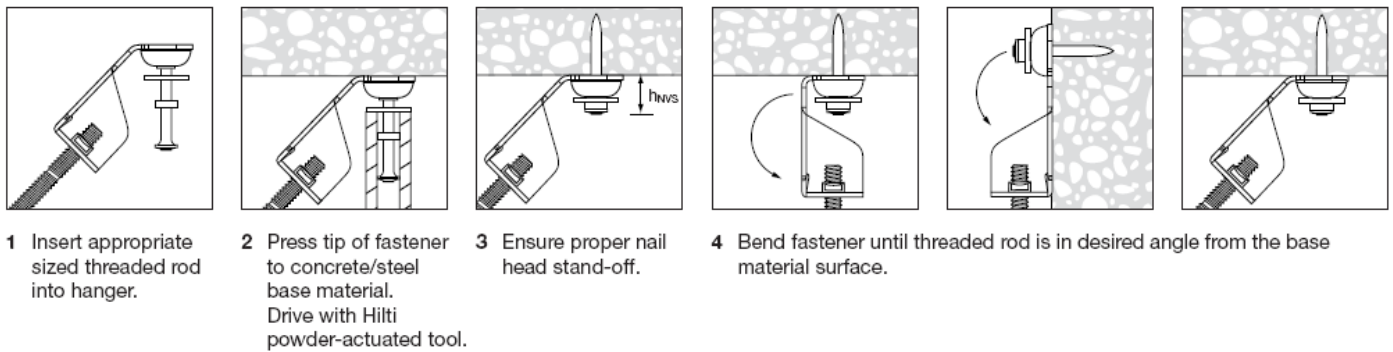

FIGURE 8—X-HS INSTALLATION INSTRUCTIONS

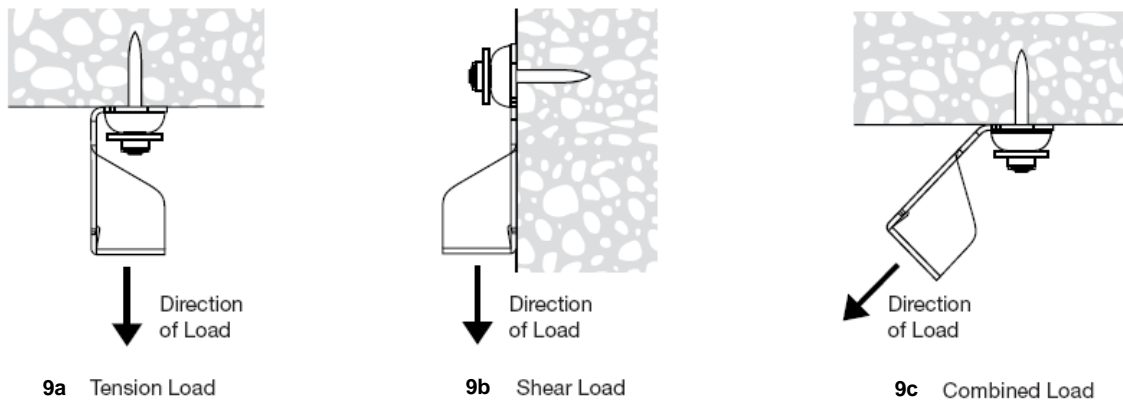

FIGURE 9—X-HS LOAD DIRECTIONS

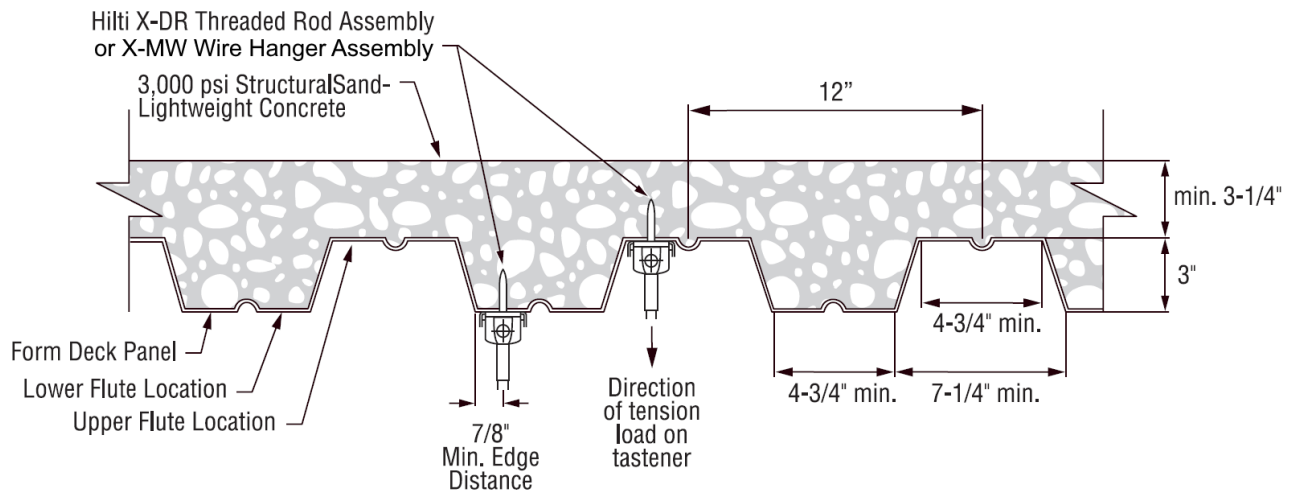
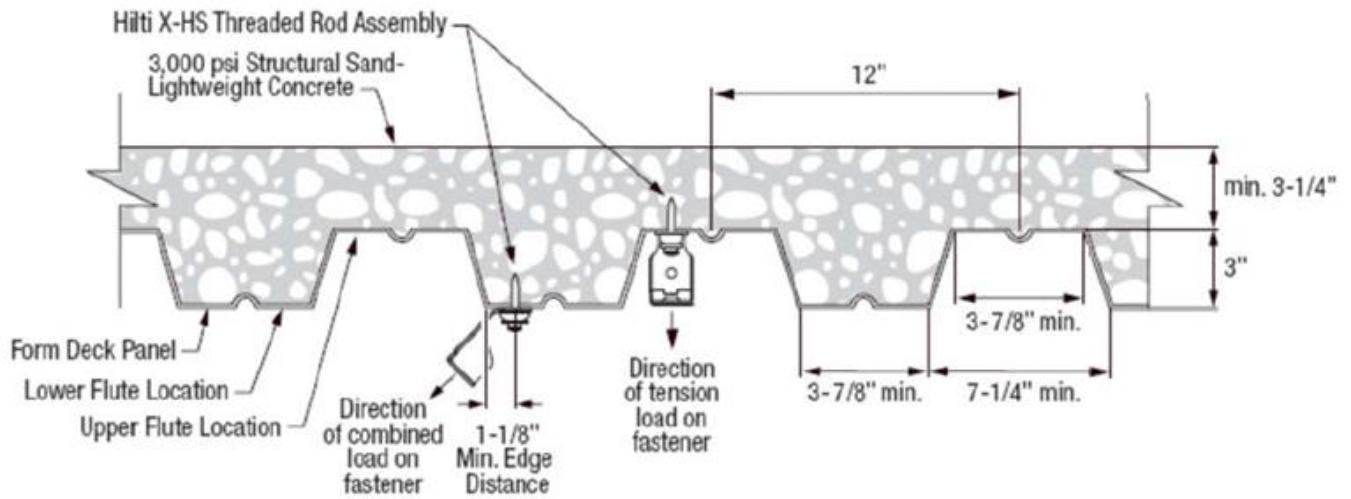
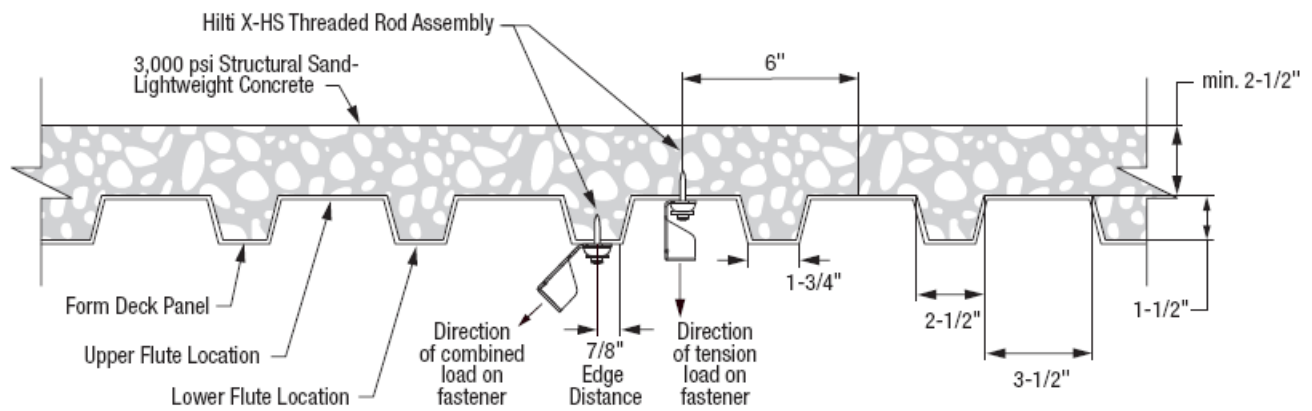

FIGURE 10 – HILTI X-DR AND X-DR MX ROD HANGER AND X-MW ALH AND X-MW MX WIRE HANGER ASSEMBLY LOCATION IN 3-INCH-DEEP COMPOSITE FLOOR DECK PANEL

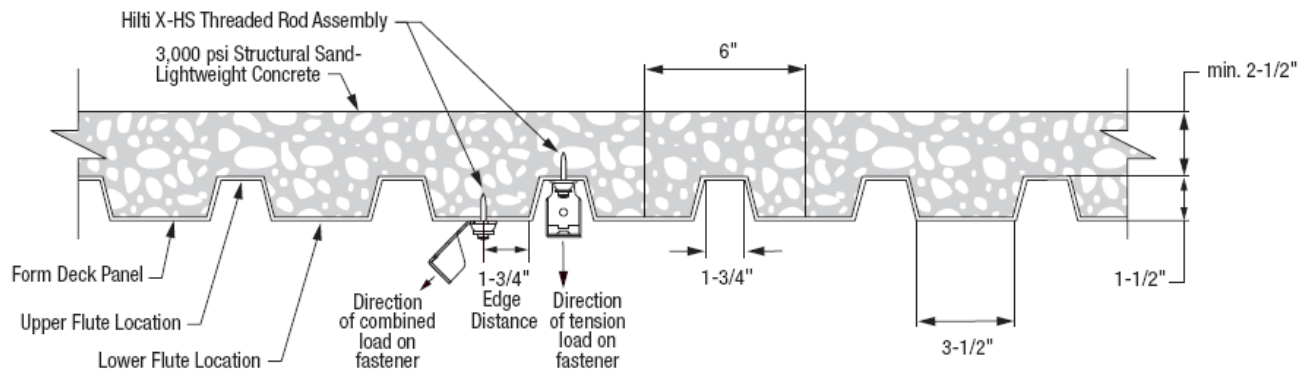



**FIGURE 11—HILTI X-HS ROD HANGER ASSEMBLY LOCATION IN 3-INCH-DEEP COMPOSITE FLOOR DECK PANEL**



**FIGURE 12—HILTI X-HS ROD HANGER ASSEMBLY LOCATION IN 1 1/2-INCH-DEEP FLOOR DECK PANEL, NORMAL DECK PANEL PROFILE ORIENTATION**



**FIGURE 13—HILTI X-HS ROD HANGER ASSEMBLY LOCATION IN 1 1/2-INCH-DEEP FLOOR DECK PANEL, INVERTED DECK PANEL PROFILE ORIENTATION**

For SI: 1 inch = 25.4 mm, 1 psi = 6895 Pa.

**DIVISION: 03 00 00—CONCRETE**  
**Section: 03 16 00—Concrete Anchors**

**DIVISION: 05 00 00—METALS**  
**Section: 05 05 23—Metal Fastenings**

**REPORT HOLDER:**

HILTI, INC.

**EVALUATION SUBJECT:**

**HILTI LOW-VELOCITY POWER-ACTUATED X-DR, X-DR MX AND X-HS ROD HANGER ASSEMBLIES AND X-MW ALH AND X-MW MX WIRE HANGER ASSEMBLIES**

## 1.0 REPORT PURPOSE AND SCOPE

**Purpose:**

The purpose of this evaluation report supplement is to indicate that the Hilti Low-Velocity Power-Actuated X-DR, X-DR MX and X-HS Rod Hanger Assemblies and X-MW and X-MW MX Wire Hanger Assemblies, described in ICC-ES evaluation report [ESR-2795](#), have also been evaluated for compliance with the codes noted below as adopted by the Los Angeles Department of Building and Safety (LADBS).

**Applicable code editions:**

- 2023 *City of Los Angeles Building Code* (LABC)
- 2023 *City of Los Angeles Residential Code* (LARC)

## 2.0 CONCLUSIONS

The Hilti Low-Velocity Power-Actuated X-DR, X-DR MX and X-HS Rod Hanger Assemblies and X-MW and X-MW MX Wire Hanger Assemblies, described in Sections 2.0 through 7.0 of evaluation report [ESR-2795](#), comply with LABC Chapters 19 and 22, and the LARC, and are subject to the conditions of use described in this supplement.

## 3.0 CONDITIONS OF USE

The Hilti Low-Velocity Power-Actuated X-DR, X-DR MX and X-HS Rod Hanger Assemblies and X-MW and X-MW MX Wire Hanger Assemblies described in this evaluation report supplement must comply with all of the following conditions:

- All applicable sections in the evaluation report [ESR-2795](#).
- The design, installation, conditions of use and identification are in accordance with the 2021 *International Building Code*® (2021 IBC) provisions noted in the evaluation report [ESR-2795](#).
- The design, installation and inspection are in accordance with additional requirements of LABC Chapters 16 and 17, as applicable.
- Under the LARC, an engineered design in accordance with LARC Section R301.1.3 must be submitted.
- The allowable values listed in the evaluation report and tables are for the rod hanger assembly or wire hanger assembly only. Connected members shall be checked for their capacity (which may govern).

This supplement expires concurrently with the evaluation report, reissued June 2023 and revised November 2023.

**DIVISION: 03 00 00—CONCRETE**

Section: 03 16 00—Concrete Anchors

**DIVISION: 05 00 00—METALS**

Section: 05 05 23—Metal Fastenings

**REPORT HOLDER:**

HILTI, INC.

**EVALUATION SUBJECT:****HILTI LOW-VELOCITY POWER-ACTUATED X-DR, X-DR MX AND X-HS ROD HANGER ASSEMBLIES AND X-MW ALH AND X-MW MX WIRE HANGER ASSEMBLIES****1.0 REPORT PURPOSE AND SCOPE****Purpose:**

The purpose of this evaluation report supplement is to indicate that the Hilti Low-Velocity Power-Actuated X-DR, X-DR MX and X-HS Rod Hanger Assemblies and X-MW and X-MW MX Wire Hanger Assemblies, addressed in ICC-ES evaluation report ESR-2795, have also been evaluated for compliance with the codes noted below.

**Applicable code editions:**

- 2023 *Florida Building Code—Building*
- 2023 *Florida Building Code—Residential*

**2.0 CONCLUSIONS**

The Hilti Low-Velocity Power-Actuated X-DR, X-DR MX and X-HS Rod Hanger Assemblies and X-MW and X-MW MX Wire Hanger Assemblies, described in Sections 2.0 through 7.0 of evaluation report ESR-2795, comply with the *Florida Building Code—Building* and the *Florida Building Code—Residential*, with the replacement of the referenced ASCE 7 edition as noted below. The design requirements must be determined in accordance with the *Florida Building Code—Building* or the *Florida Building Code—Residential*, as applicable. The installation requirements noted in ICC-ES evaluation report ESR-2795 for the 2021 *International Building Code*® meet the requirements of the *Florida Building Code—Building* or the *Florida Building Code—Residential*, as applicable.

References to ASCE 7-16/S1 in ESR-2795 shall be replaced with ASCE 7-22. This is necessary as the 2023 *Florida Building Code—Building* references ASCE 7-22 and the 2021 *International Building Code*® references ASCE 7-16/S1.

Use of the Hilti rod hanger assemblies and wire hanger assemblies has also been found to be in compliance with the High-Velocity Hurricane Zone provisions of the *Florida Building Code—Building* and the *Florida Building Code—Residential* under the following conditions:

- The assemblies have not been evaluated for use as cast-in-place anchors for compliance with the High-Velocity Hurricane Zone provisions, and this use is outside the scope of this supplement.

For products falling under Florida Rule 61G20-3, verification that the report holder's quality assurance program is audited by a quality assurance entity approved by the Florida Building Commission for the type of inspections being conducted is the responsibility of an approved validation entity (or the code official, when the report holder does not possess an approval by the Commission).

This supplement expires concurrently with the evaluation report, reissued June 2023 and revised April 2024.