

SF 4000-A



Operating instructions

1-8



340751

HILTI

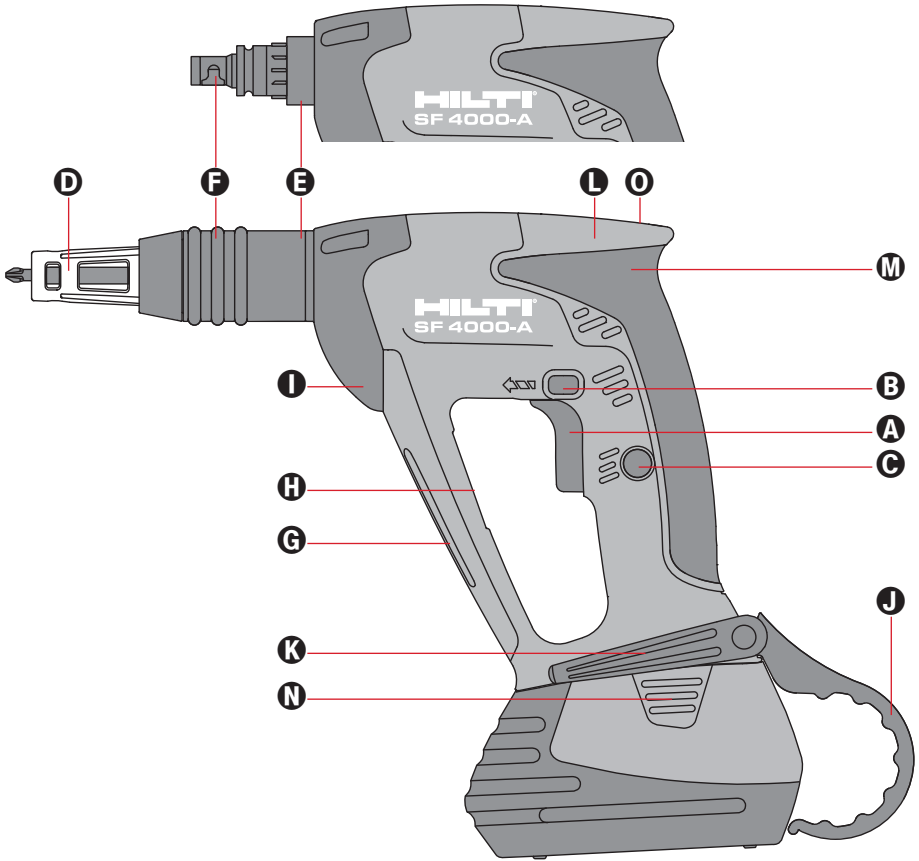

This Product is Certified
Ce produit est certifié
Este producto esta certificado
Este producto está certificado



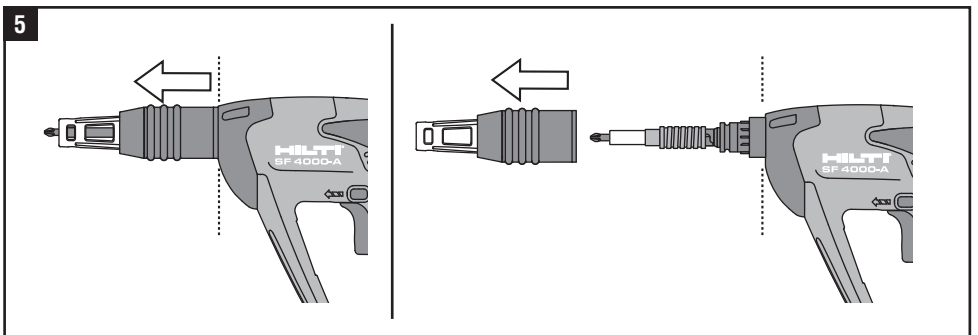
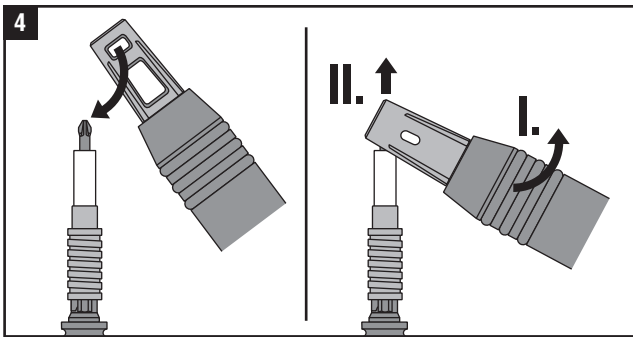
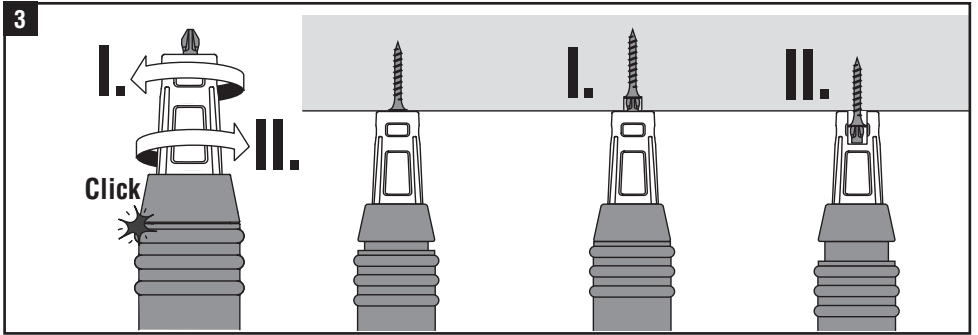
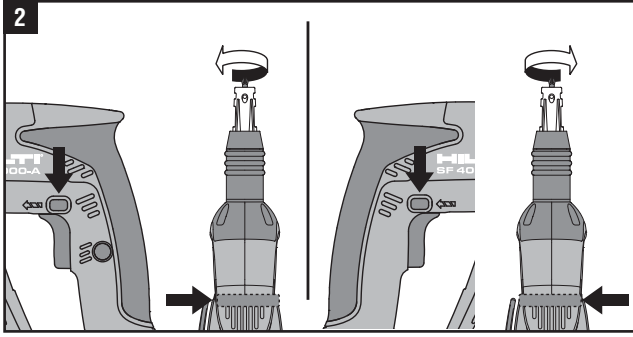

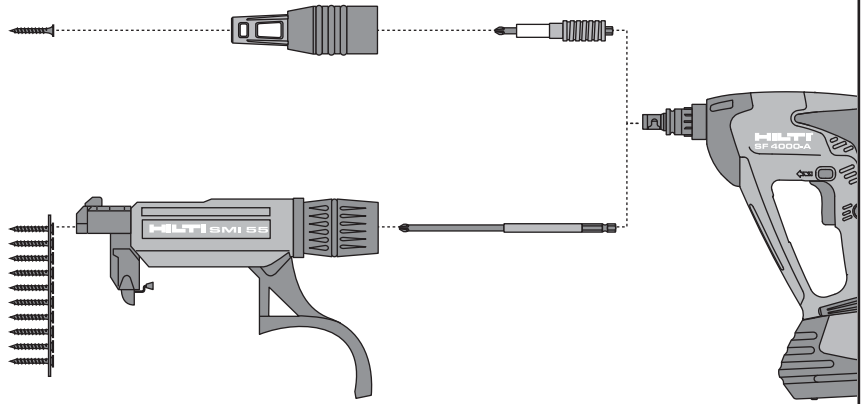

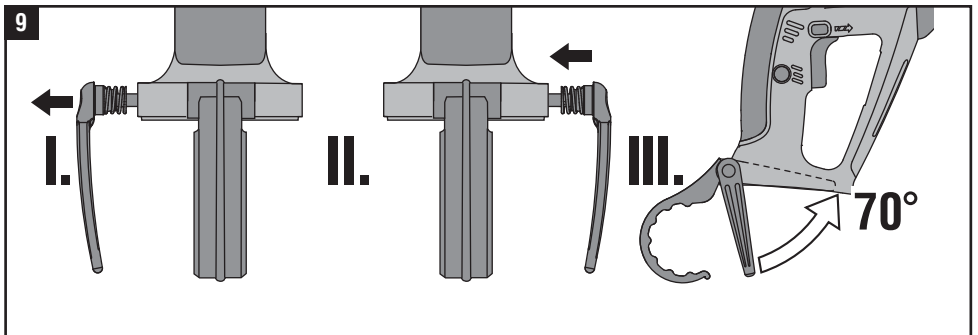
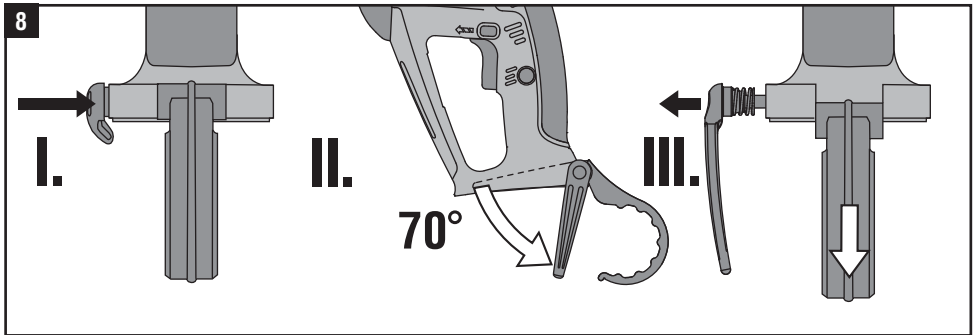
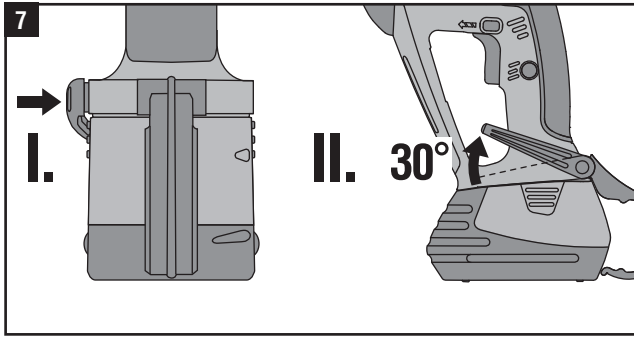

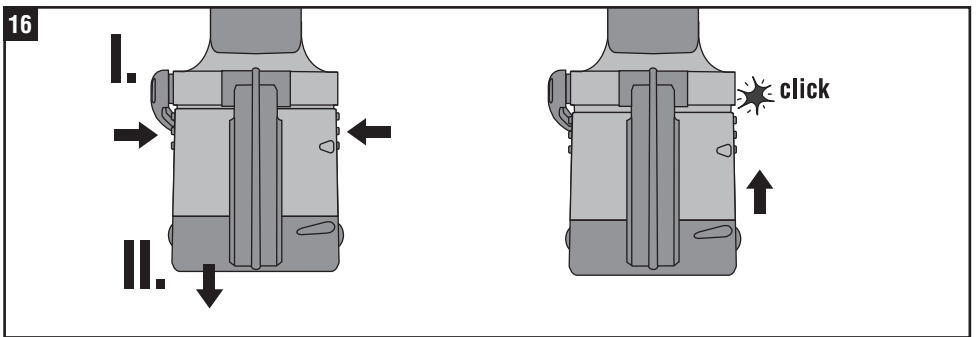
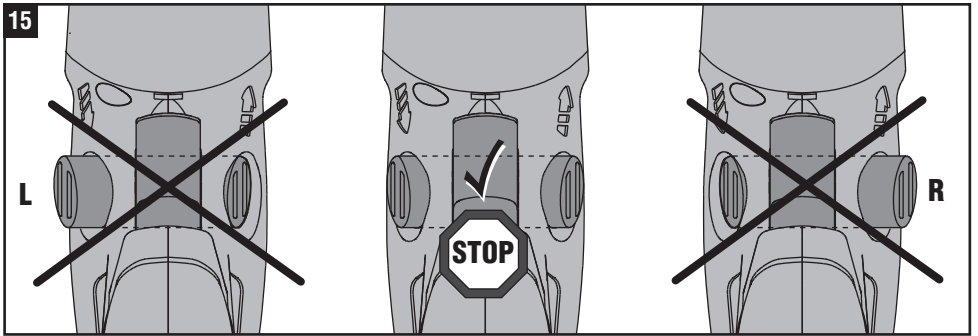
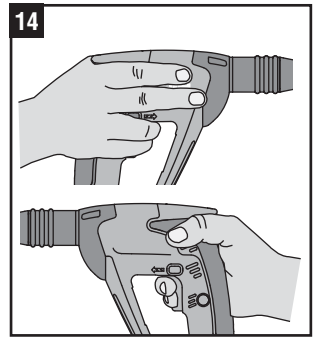
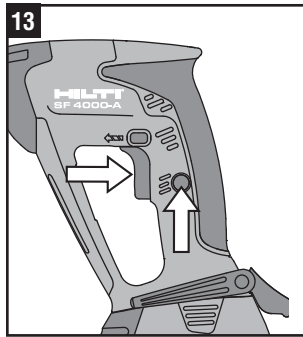
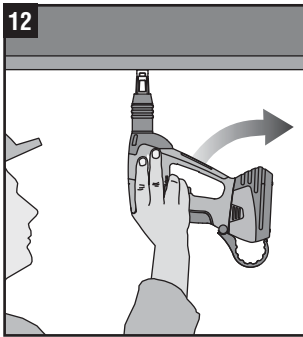
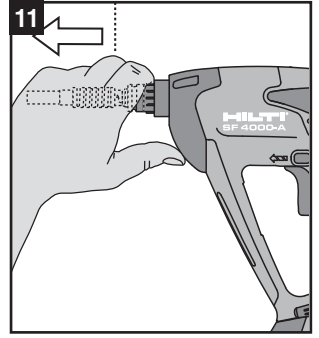
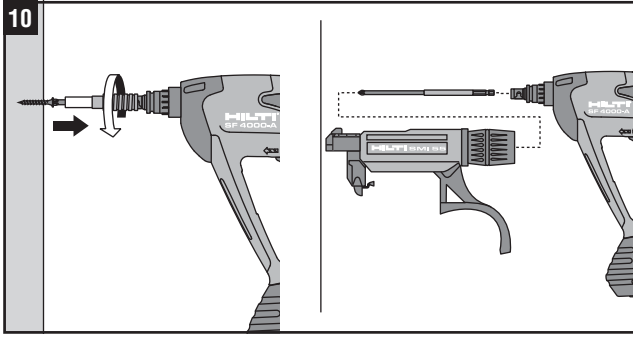

SF 4000-A drywall screwdriver

It is essential that the operating instructions are read before the tool is operated for the first time.

Always keep these operating instructions with the tool.

Ensure that the operating instructions are with the tool when it is given to other persons.

Operating controls and components 1

- A** On / off switch (with electronic speed control)
- B** Forward / reverse switch
- C** Lockbutton for sustained operation
- D** Adjustable depth gauge (with bit change function)
- E** Screwdriver / accessory interface (click connection)
- F** 1/4" chuck (for bit holder, magazine bit)
- G** Cooling air exit
- H** Rating plate
- I** Clutch system / gearing
- J** Scaffolding hook
- K** Belt hook
- L** Motor
- M** Grip
- N** Battery release button
- O** Motor cooling air intake

Contents	Page
1. General information	1
2. General safety rules	2
3. Specific safety rules and symbols	3
4. Functional description	4
5. Technical data	5
6. Setting-up operation	5
7. Operation	6
8. Care and maintenance	7
9. Accessories	8
10. Troubleshooting	8
11. Manufacturer's warranty – tools	9
12. Disposal	9

1. General information

1.1 Indication of possible danger

CAUTION

In the text of these operating instructions, the word -CAUTION- is used to draw attention to a potentially dangerous situation which could lead to minor personal injury or damage to the equipment or other property.

1.2 Pictograms

Warning signs



General warning



Warning: electricity



Warning: caustic substances

Symbols



Read the operating instructions before use.

1 These numbers refer to the corresponding illustrations. The illustrations can be found on the fold-out cover pages. Keep these pages open while studying the operating instructions.

In these operating instructions, the designation "the tool" always refers to the SF 4000-A with battery (fitted).

Location of identification data on the tool

The type designation, item number, year of manufacture and revision level are printed on the type plate on the tool. The serial number can be found on the left side of the motor housing. Make a note of this information in your operating instructions and always refer to it when making an enquiry to your Hilti representative or service department.

Type: _____

Serial no.: _____

2. GENERAL SAFETY RULES

2.1 WARNING!

READ AND UNDERSTAND ALL INSTRUCTIONS

Failure to follow all instructions listed below, may result in electric shock, fire and/or serious personal injury.

SAVE THESE INSTRUCTIONS.

2.2 Work Area

Keep your work area clean and well lit.

Cluttered benches and dark areas invite accidents.

Do not operate power tools in explosive atmospheres, such as in the presence of flammable liquids, gases, or dust.

Power tools create sparks which may ignite the dust or fumes.

Keep bystanders, children, and visitors away while operating a power tool.

Distractions can cause you to lose control.

2.3 Electrical safety

Do not abuse the cord. Never use the cord to carry the tool. Keep cord away from heat, oil, sharp edges, or moving parts. Replace damaged cords immediately.

Damaged cords may create a fire.

A battery operated tool with integral batteries or a separate battery pack must be recharged only with the specified charger for the battery.

A charger that may be suitable for one type of battery may create a risk of fire when used with another battery.

Use battery operated tool only with specifically designated battery pack.

Use of any other batteries may create a risk of fire.

2.4 Personal safety

Stay alert, watch what you are doing, and use common sense when operating a power tool. Do not use tool while tired or under the influence of drugs, alcohol, or medication.

A moment of inattention while operating power tools may result in serious personal injury.

Dress properly. Do not wear loose clothing or jewelry. Contain long hair. Keep your hair, clothing, and gloves away from moving parts.

Loose clothes, jewelry, or long hair can be caught in moving parts.

Avoid accidental starting. Be sure switch is in the locked or off position before inserting battery pack.

Carrying tools with your finger on the switch or inserting the battery pack into a tool with the switch on invites accidents.

Remove adjusting keys or wrenches before turning the tool on.

A wrench or a key that is left attached to a rotating part of the tool may result in personal injury.

Do not overreach. Keep proper footing and balance at all times.

Proper footing and balance enable better control of the tool in unexpected situations.

Use safety equipment. Always wear eye protection.

Dust mask, non-skid safety shoes, hard hat, or hearing protection must be used for appropriate conditions.

2.5 Tool Use and Care

Use clamps or other practical way to secure and support the workpiece to a stable platform.

Holding the work by hand or against your body is unstable and may lead to loss of control.

Do not force tool. Use the correct tool for your application.

The correct tool will do the job better and safer at the rate for which it is designed.

Do not use tool if switch does not turn it on or off.

A tool that cannot be controlled with the switch is dangerous and must be repaired.

Disconnect battery pack from tool or place the switch in the locked or off position before making any adjustments, changing accessories, or storing the tool.

Such preventive safety measures reduce the risk of starting the tool accidentally.

Store idle tools out of reach of children and other untrained persons.

Tools are dangerous in the hands of untrained users.

When battery pack is not in use, keep it away from other metal objects like: paper clips, coins, keys, nails, screws, or other small metal objects that can make a connection from one terminal to another.

Shorting the battery terminals together may cause sparks, burns, or a fire.

Maintain tools with care. Keep cutting tools sharp and clean.

Properly maintained insert tools with sharp cutting edge are less likely to bind and are easier to control.

Check for misalignment or binding of moving parts, breakage of parts, and any other condition that may

affect the tool's operation. If damaged, have the tool serviced before using.

Many accidents are caused by poorly maintained tools.

Use only accessories that are recommended by the manufacturer for your model.

Accessories that may be suitable for one tool may create a risk of injury when used on another tool.

2.6 Service

Tool service must be performed only by qualified repair personnel.

Service or maintenance performed by unqualified personnel may result in a risk of injury.

When servicing a tool, use only identical replacement parts. Follow instructions in the Maintenance section of this manual.

Use of unauthorized parts or failure to follow Maintenance Instructions may create a risk of shock or injury.

3. SPECIFIC SAFETY RULES AND SYMBOLS

Hold tool by insulated gripping surfaces when performing an operation where the cutting tool may contact hidden wiring.

Contact with a "live" wire will also make exposed metal parts of the tool "live" and shock the operator.

WARNING: Some dust created by grinding, sanding, cutting and drilling contains chemicals known to cause cancer, birth defects, infertility or other reproductive harm; or serious and permanent respiratory or other injury. Some examples of these chemicals are: lead from leadbased paints, crystalline silica from bricks, concrete and other masonry products and natural stone, arsenic and chromium from chemically treated lumber. Your risk from these exposures varies, depending on how often you do this type of work. **To reduce exposure to these chemicals, the operator and bystanders should work in a well-ventilated area, work with approved safety equipment, such as respiratory protection appropriate for the type of dust generated, and designed to filter out microscopic particles and direct dust away from the face and body. Avoid prolonged contact with dust. Wear protective clothing and wash exposed areas with soap and water.** Allowing dust to get into your mouth, eyes, or to remain on your skin may promote absorption of harmful chemicals.

The tool is not intended for use by children, by debilitated persons or those who have received no instruction or training.

Children must be instructed not to play with the tool.

Take care to avoid concealed cables and pipes. Check the area in which you are working beforehand, e. g. using a metal detector.

Concealed electric cables or gas and water pipes present a serious hazard if damaged while you are working.

Do not expose the tool to rain. Do not use the tool in damp or wet locations.

Water can damage the tool and battery pack.

Ensure that the insert tools (drill bits, etc.) are equipped with the appropriate connection end for the chuck system in use and that they are locked in position correctly in the chuck.

A loose insert tool presents a risk of injury.

Check of proper battery seating in the tool.

If the battery is not properly inserted, it can drop out when working and cause an injury.

Do not carry the tool by the depth gauge (the snaplock connection may release unexpectedly).

Liquids

Caustic liquids may leak from defective batteries.

Avoid contact with these liquids.

In the event of contact with the skin, wash the area affected with soap and plenty of water. Should the liquid come into contact with the eyes, flush the eyes with water immediately and subsequently consult a doctor.

Obligation signs



Wear eye protection



Wear breathing protection



Wear ear protection

Symbols used on the tool:

V volts
= = = direct current



Waste material should be recycled.



The disposal of batteries with general refuse is not permissible.

4. Functional description

The SF 4000-A is a battery-powered drywall screwdriver with automatic (jet) coupling designed for use by professional drywall installers. For optimum efficiency and comfort in use, we recommend that the tool is held in line with the forearm (in-line grip) **14**. The motor cooling air is drawn in through the slots **1** and is expelled from the tool through the air exit **6**. The tool is suitable for use by both right- and left-handed users. The ergonomic, rubber-padded grip reduces fatigue and ensures that the tool can be held securely.

The following items are supplied: electric screwdriver with Phillips no. 2 bit and magnetic bit holder, 2 SFB 180 or SFB 185 batteries, C7/24 charger, 2 operating instructions, packed in a plastic toolbox. Alternatively, the electric screwdriver may be supplied with a Phillips no. 2 bit and magnetic bit holder, operating instructions, packed in a cardboard box.

See figure **1** and the explanations of operating controls and components on page 1.

Main features of the tool

- Vibration-absorbing grip (synthetic rubber)
- Smooth speed control
- Gearing and clutch with permanent lubrication
- Automatic cut-out carbon brushes
- Coupling with jet function
- Scaffolding hook and belt hook (pivoting and removable)
- Lockbutton for sustained operation
- Forward / reverse rotation
- Adjustable depth gauge
- Cooling air guidance (air exit)

Use of tool for intended purpose

Main application	Type of screw
Drywall panels on metal framing ≤ 20 ga. (≤ 0.88 mm)	Drywall screw with needle point, type S-DS01
Drywall panels on metal framing ≤ 20 –14 ga. (≤ 2.25 mm)	Drywall screw with drill point, type S-DD01
Fastening metal framing parts to each other (max. fastened thickness 12–13 ga. 2.50 mm)	Drywall screw with drill point, types S-DD02 and S-DD03
Drywall panels on timber framing	Drywall screw with needle point, type S-DS03
Drywall panels on metal framing ≤ 20 ga. (≤ 0.88 mm) and timber framing	Drywall screw with needle point, type S-DS14
Particle board on timber framing	Drywall screw with needle point, type S-DS03

The tool can also be used with the SMI 55 magazine and corresponding magazined screws for the intended applications. Please refer to the operating instructions for the SMI 55 drywall screw magazine.

5. Technical data

SF4000-A screwdriver

Nominal voltage	18 V ---
Chuck	1/4" DIN 3126 / ISO 1173
Max. torque	< 6 Nm
Speed under no load	0–4000 r.p.m.
Speed control	Electronic, by on / off switch
Forward / reverse rotation	Switch interlock prevents activation while running
Dimensions (LxWxH)	14.2x2.7x10.7" (361x69x272 mm)
Weight with battery	5.3 lbs (2.4 kg)
Gearing with dust-tight enclosure and permanent lubrication (maintenance free)	

Battery	SFB 180	SFB 185
Nominal voltage	18 V ---	18 V ---
Battery capacity	18 Vx2.0 Ah = 36 Wh	18 Vx3.0 Ah = 54 Wh
Weight	2.3 lbs (1.05 kg)	2.5 lbs (1.15 kg)
Temperature monitoring	yes	yes
Type of cell	Nickel-cadmium SCB C design	Nickel-metal hydride SCB C design
Number of cells	15	15

Right of technical changes reserved

6. Setting-up operation

1. It is essential that the safety rules printed in these operating instructions are read and observed.
2. A new battery must be charged correctly for the first time before use:
 - charged normally for 24 hours with the SFC 7/18H charger, or
 - charged for 12 hours using the conditioning function of the SFC 7/18, C7/24, C7/36-ACS or TCU 7/36 charger. This will ensure that the cells form correctly. Incorrect initial charging may have a permanent, negative effect on battery capacity.

Additional instructions

- The tool may be used only with SFB 180 or SFB 185 batteries.
- Battery performance drops at low temperatures.
- Batteries should be stored at room temperature.
- Never store batteries where they are exposed to the heat of the sun, on a radiator, behind a motor vehicle windscreen or at a window.
- Never use the battery until the cells become fully discharged. Change to the second battery as soon as a drop in performance is noticed and recharge the battery immediately so that it is ready for re-use.
- Use bits with a standard 1/4" hex. shank.

The battery cannot be charged through the belt adaptor. When charging, always insert the battery directly in the charger.

7. Operation

Setting the depth gauge (screwdriving depth) **3**

By adjusting the depth gauge, the screw can be driven flush, beneath the surface or left projecting. Each increment is equal to an adjustment of ± 0.25 mm.

- Turn the depth gauge to the left
 - = The screw is driven deeper I.
- Turn the depth gauge to the right
 - = The screw is driven less deeply II.

Setting forward or reverse rotation **2 15**

The direction of rotation of the driving spindle can be selected by operating the forward / reverse push switch **2**. An interlock prevents operation of the switch while the motor is running. When in the middle position, the on / off switch is locked **15**.

- Push the forward / reverse switch to the right (tool in the working position)
 - = reverse I.
- Push the forward / reverse switch to the left (tool in the working position)
 - = forwards II.

Changing the bit **4**

1. Grip the depth gauge and pull it forwards until the snap-lock connection releases. The depth gauge can then be pulled off towards the front end of the tool **5**.
2. Position the depth gauge on the worn bit **4**.
3. Pull the depth gauge upwards and pull out the bit towards the front end of the tool **4**.
4. Insert a new bit.
5. Position the depth gauge on the tool and press it in until it engages.

Changing the bit holder **11**

1. Grip the depth gauge and pull it forwards until the snap-lock connection releases. The depth gauge can then be pulled off towards the front end of the tool **5**.
2. Grip the plastic part of the bit holder and pull it towards the front end of the tool while pressing it away from the gear housing **11**.
3. Insert a new bit holder.
4. Position the depth gauge on the tool and press it in until it engages.

Switching on / off

1. Use the forward / reverse push switch to select the direction of rotation.
2. The speed of the tool can be controlled smoothly between zero and maximum by pressing the on / off switch slowly.

Should the motor stall for longer than 2–3 seconds, the tool must be switched off in order to avoid damage to it.

Selecting sustained operation **18**

The lockbutton for sustained operation can be used to

keep the motor running constantly at the optimal speed with optimal motor cooling.

1. Press the on / off switch and hold it in the depressed position.
2. Press the lockbutton.
3. Release the on / off switch.
4. Release the lockbutton.

Ending sustained operation **18**

1. Press the on / off switch as far as it will go. The lockbutton returns to its original position, thus ending sustained operation mode.

The interface between the tool and the depth gauge

1. Grip the depth gauge and pull it forwards until the snap-lock connection releases. The depth gauge can then be pulled off towards the front end of the tool **5**.
 - The drive spindle is then exposed and the tool can be used in reverse rotation for removing screws **10** I.

This also facilitates:

- changing the bit **4** or bit holder **11**,
 - attaching the SMI55 magazine **10** II,
 - re-tightening screws.
2. Position the depth gauge on the tool and press it in until it engages. Take care when attaching the depth gauge.

Belt hook **7 9**

The belt hook can be used to attach the tool on a belt in a position close to the body. To achieve the optimal position, the belt hook must be pivoted 30° from the horizontal position, in an upwards direction **7**.

1. Press the button I.
2. Pivot the belt hook through 30° from the horizontal position, in an upwards direction, until it engages II.

The belt hook may also be fitted on the other side of the tool for use by left-handed persons **9**.

1. Press the button I.
2. Pivot the belt hook through 70° from the horizontal position, in a downwards direction I.
3. Pull the belt hook out of its guide.
4. Push the belt hook into the guide II on the other side of the tool. The scaffolding hook must also lie against the battery, so that the guide slots for the securing pin in the motor housing and scaffolding hook are in alignment III.
5. Pivot the belt hook back through 70° into the horizontal position, until it engages III.

Make sure that the belt hook is securely fixed.

Scaffolding hook **8**

The scaffolding hook provides a convenient means of temporarily attaching the tool to objects at the work-

place, e.g. to free the hands for other tasks. The scaffolding hook can be removed completely if not required.

Removing the scaffolding hook

1. Press the button I.
2. Pivot the belt hook through 70° from the horizontal position, in a downwards direction I.
3. Pull the belt hook out of its guide III.
4. Remove the scaffolding hook III.
5. Push the belt hook into the guide III.
6. Pivot the belt hook back through 70° into the horizontal position, until it engages II.

Fitting the scaffolding hook

1. Press the button I.
2. Pivot the belt hook through 70° from the horizontal position, in a downwards direction II.
3. Pull the belt hook out of its guide III.
4. Fit the scaffolding hook. The scaffolding hook must lie against the battery so that the guide slots for the securing pin in the motor housing and scaffolding hook are in alignment.
5. Push the belt hook back into its guide III.
6. Pivot the belt hook back through 70° into the horizontal position, until it engages II.

Make sure that the scaffolding hook is securely fixed. Only use scaffolding hook as long as necessary. Put the tool in a safe place when leaving the jobsite/workplace.

Removing the battery (2-finger operation)

1. Press in both release buttons.
2. Pull the battery downwards out of the tool.

Fitting the battery

Use only Hilti SFB 180 or SFB 185 batteries. Push the battery into the tool from below until it is heard to engage.

Charging the battery

Use only the Hilti SFC 7/18H, SFC 7/18 or TCU 7/36, C7/24, C7/36-ACS charger.

Ensure that the outer surfaces of the battery are clean and dry before inserting it in the corresponding charger. Incorrect use may lead to electric shocks, overheating of the battery or leakage of a caustic liquid from the battery. Read the operating instructions for the charger before beginning charging.

8. Care and maintenance

8.1 Care of insert tools

Remove any dirt adhering to the surface of the insert tools and protect them from corrosion by rubbing them with an oily cloth from time to time.

8.2 Care of the tool

Before cleaning, remove the battery from the tool in order to prevent inadvertent starting.

-CAUTION-

Keep the power tool, especially its grip surfaces, clean and free from oil and grease. Do not use cleaning agents which contain silicone.

The outer casing of the tool is made from impact-resistant plastic. Sections of the grip are made from a synthetic rubber material. Never operate the tool when the ventilation slots are blocked. Clean the ventilation slots carefully using a dry brush. Do not permit foreign objects to enter the interior of the tool. Clean the outside of the tool at regular intervals with a slightly damp cloth. Do not use a spray, steam pressure cleaning equipment or running water for cleaning. This may negatively affect the electrical safety of the tool.

8.3 Maintenance

Check all external parts of the tool for damage at regular intervals and check that all controls operate faultlessly. Do not operate the tool when parts are damaged or when the controls do not operate faultlessly. If necessary, have the tool repaired at a Hilti service centre. Electrical parts of the tool may be repaired only by trained electrical specialists.

8.4 Care of the battery

Keep the electrical contacts free from dust, oil and grease. If necessary, use a clean cloth to clean the contact surfaces.

Do not operate the tool until the battery is completely discharged as this may damage the battery cells. Recharge the battery as soon as a drop in performance is noticed. At monthly intervals or, at the latest, when battery capacity drops significantly, the battery should be conditioned as follows:

- by charging with the SFC 7/18 H charger for 24 hours in normal charging mode, or
- by charging with the SFC 7/18, C7/24, C7/36-ACS or TCU 7/36 charger for 12 hours in conditioning mode.

If, after conditioning, battery capacity is still unsatisfactory, we recommend returning the battery to Hilti for diagnosis.

8.5 Checking the tool after care and maintenance

After carrying out care and maintenance work on the tool, check that all protective and safety devices are fitted and that they function faultlessly.

9. Accessories

- Depth gauge, alu 75 mm S-GDA 11×75
- Long bit holder, magnetic S-BHP 75M
- Phillips no. 2 bit
- Belt hook
- Scaffolding hook
- SFB 180 or SFB 185 battery
- Toolbox
- Belt adaptor SFB 180 / 185 BAP

10. Troubleshooting

Fault	Possible cause	Remedy
Tool doesn't run.	Battery is discharged or not correctly fitted.	The battery must engage with an audible "click" and must be charged.
On/off switch cannot be pressed (locked).	Forward / reverse switch in middle position (transport lock).	Move the forward / reverse switch to the left or right.
Tool runs but screws cannot be driven.	Forward / reverse switch set to wrong direction of rotation.	Move the forward / reverse switch to the left.
Speed suddenly drops.	Battery is almost exhausted.	Replace and charge the exhausted battery.
Battery becomes discharged more quickly than usual.	Battery condition is not optimal.	Charge the battery using the conditioning function (see operating instructions for the charger).
Switch speed control has no effect (only on / off function).	The tool has been overloaded.	Contact Hilti Service.
Battery doesn't engage with an audible "click".	Dirt on the battery locking lug.	Clean the battery locking lug or contact Hilti Service.
Tool or battery becomes very warm (overheats).	Electrical fault	Switch off the tool immediately. Remove the battery and contact Hilti Service.
Belt hook doesn't hold.	Belt hook is not attached correctly.	Refer to the operating instructions.

11. Manufacturer's warranty – tools

Hilti warrants that the tool supplied is free of defects in material and workmanship. This warranty is valid so long as the tool is operated and handled correctly, cleaned and serviced properly and in accordance with the Hilti Operating Instructions, and the technical system is maintained. This means that only original Hilti consumables, components and spare parts may be used in the tool.

This warranty provides the free-of-charge repair or replacement of defective parts only over the entire lifespan of the tool. Parts requiring repair or replacement as a result of normal wear and tear are not covered by this warranty.

Additional claims are excluded, unless stringent national rules prohibit such exclusion. In particular,

Hilti is not obligated for direct, indirect, incidental or consequential damages, losses or expenses in connection with, or by reason of, the use of, or inability to use the tool for any purpose. Implied warranties of merchantability or fitness for a particular purpose are specifically excluded.

For repair or replacement, send tool or related parts immediately upon discovery of the defect to the address of the local Hilti marketing organization provided.

This constitutes Hilti's entire obligation with regard to warranty and supersedes all prior or contemporaneous comments and oral or written agreements concerning warranties.

12. Disposal



Most of the materials from which Hilti power tools are manufactured can be recycled. The materials must be correctly separated before they can be recycled. In many countries, Hilti has already made arrangements for taking back your old electric tools for recycling. Please ask your Hilti customer service department or Hilti sales representative for further information.

Disposal

Batteries

The Hilti SFB 180 battery has 15 nickel-cadmium cells.

The Hilti SFB 185 battery has 15 nickel-metal hydrid cells.

Both you and Hilti bear the responsibility for recycling of the worn-out batteries in keeping with environmental protection requirements.

Important: Do not throw worn-out batteries into household waste, a fire or water. Dispose of the batteries in accordance with national regulations or return them to Hilti.



Hilti Corporation

LI-9494 Schaan

Tel.: +423 / 234 21 11

Fax: +423 / 234 29 65

www.hilti.com